

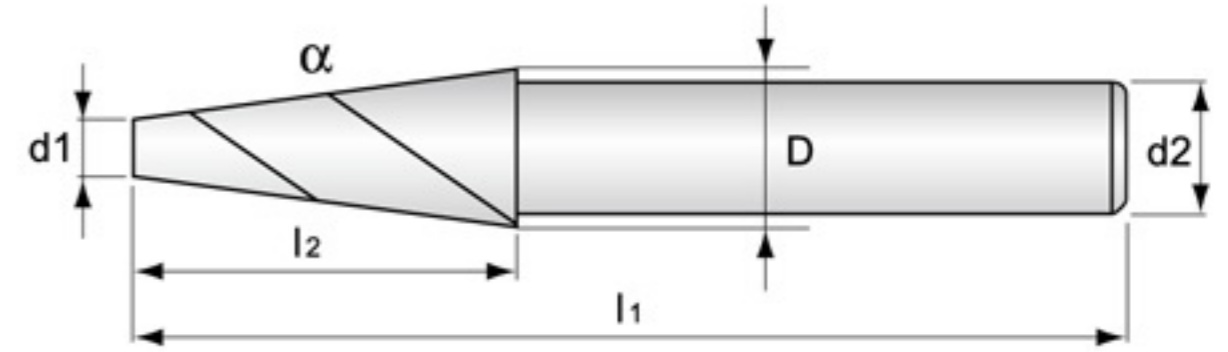

High Speed Cutting  
& High Hard Cutting



### Micro Diameter

Type No. 型號	Diameter 先徑端 d1	Flute Length 刃長 l2	Taper Angle 斜度 α	Large Mill Dia. 粗端徑 D	O. A. L. 全長 l1	Shank Dia. 柄徑 d2
4TPM3ø0.5°	3.0	10	0.5°	3.17	50	4
4TPM3ø1°	3.0	10	1°	3.35	50	4
4TPM3ø1.5°	3.0	10	1.5°	3.52	50	4
4TPM3ø2°	3.0	10	2°	3.07	50	4
4TPM3ø3°	3.0	10	3°	4.05	50	6
4TPM3ø5°	3.0	10	5°	4.75	50	6
4TPM4ø0.5°	4.0	15	0.5°	4.26	50	6
4TPM4ø1°	4.0	15	1°	4.52	50	6
4TPM4ø1.5°	4.0	15	1.5°	4.79	50	6
4TPM4ø2°	4.0	15	2°	5.05	50	6
4TPM4ø3°	4.0	15	3°	5.57	50	6
4TPM4ø5°	4.0	15	5°	6.62	60	8
4TPM5ø0.5°	5.0	20	0.5°	5.35	50	6
4TPM5ø1°	5.0	20	1°	5.70	50	6
4TPM5ø1.5°	5.0	20	1.5°	6.05	60	8
4TPM5ø2°	5.0	20	2°	6.40	60	8
4TPM5ø3°	5.0	20	3°	7.10	60	8
4TPM5ø5°	5.0	20	5°	8.50	75	10
4TPM6ø0.5°	6.0	20	0.5°	6.35	75	8
4TPM6ø1°	6.0	20	1°	6.70	75	8
4TPM6ø1.5°	6.0	20	1.5°	7.05	75	8
4TPM6ø2°	6.0	20	2°	7.40	75	8
4TPM6ø3°	6.0	20	3°	8.10	75	10
4TPM6ø5°	6.0	20	5°	9.50	75	10
4TPM8ø0.5°	8.0	25	0.5°	8.44	75	10
4TPM8ø1°	8.0	25	1°	8.87	75	10
4TPM8ø1.5°	8.0	25	1.5°	9.31	75	10
4TPM8ø2°	8.0	25	2°	9.75	75	10
4TPM8ø3°	8.0	25	3°	10.62	75	12
4TPM8ø5°	8.0	25	5°	12.37	100	16
4TPM10ø0.5°	10.0	35	0.5°	10.61	100	16
4TPM10ø1°	10.0	35	1°	11.22	100	16
4TPM10ø1.5°	10.0	35	1.5°	11.83	100	16
4TPM10ø2°	10.0	35	2°	12.44	100	16
4TPM10ø3°	10.0	35	3°	13.67	100	16
4TPM10ø5°	10.0	35	5°	16.00	100	16