

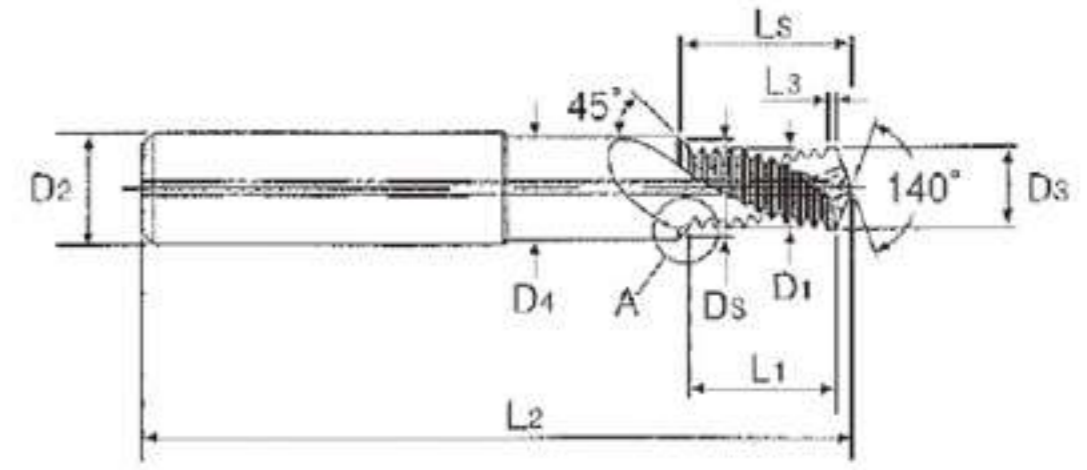

High Speed Cutting
& High Hard Cutting



Micro Diameter



Type No. 型號	Nominal Diameter [D] 直徑	Pitch 螺紋間距	Cutter Diameter 牙徑	Shank Diameter 柄徑	Effect Diameter 倒角外徑	Drill Diameter 最大外徑	Max. C'sink 倒角外徑的柄徑	Thread Length 螺紋長	Effect Length 有效長	Drill Length 前端刃長	Over All Length 全長
		P	D1	D2	Ds	D3	D4	L1	Ls	L3	L2
CMTCM6	M6	1.0	4.75	8	6.3	5.00	6.6	13.00	14.68	1.00	62
CMTCM8	M8	1.25	6.35	10	8.3	6.75	9.0	16.27	18.48	1.25	74.0
CMTCM10	M10	1.5	8.50	12	10.3	8.50	11.0	21.05	23.77	1.50	79.0
CMTCM12	M12	1.75	10.25	14	12.3	10.25	13.5	24.21	27.25	1.50	89.0
CMTCM14	M14	2.0	12.00	16	14.3	12.00	15.5	29.58	33.32	1.50	102.0

New