

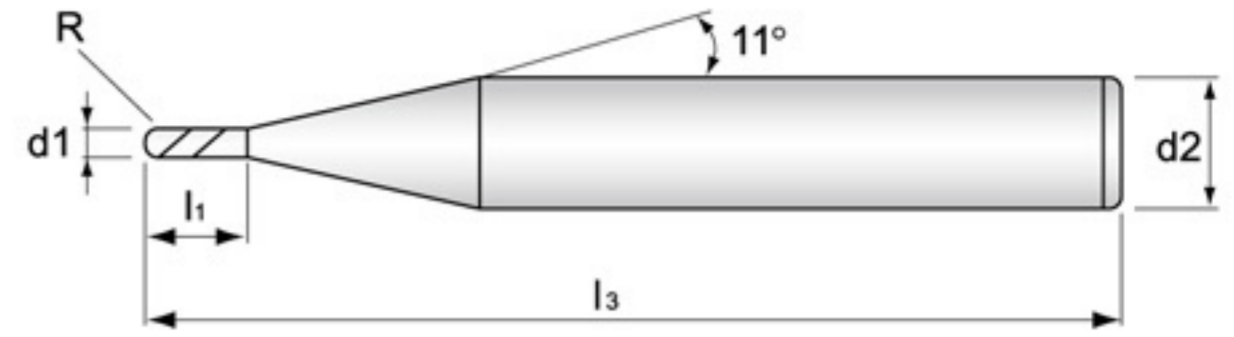

High Speed Cutting  
& High Hard Cutting



### Micro Diameter

Type No. 型號	Diameter 刃徑 d1	Flute Length 刃長 l1	O. A. L. 全長 l3	Shank Dia. 柄徑 d2
MR2002-3	R 0.10	0.4	50	3
MR2003-3	R 0.15	0.6	50	3
MR2004-3	R 0.20	0.8	50	3
MR2005-3	R 0.25	1.0	50	3
MR2006-3	R 0.30	1.2	50	3
MR2007-3	R 0.35	1.4	50	3
MR2008-3	R 0.40	1.6	50	3
MR2009-3	R 0.45	1.8	50	3
MR2002	R 0.10	0.4	50	4
MR2003	R 0.15	0.6	50	4
MR2004	R 0.20	0.8	50	4
MR2005	R 0.25	1.0	50	4
MR2006	R 0.30	1.2	50	4
MR2007	R 0.35	1.4	50	4
MR2008	R 0.40	1.6	50	4
MR2009	R 0.45	1.8	50	4
MR2012	R 0.60	2.4	50	4
MR2014	R 0.70	2.8	50	4
MR2016	R 0.80	3.2	50	4
MR2018	R 0.90	3.6	50	4

d1 (mm)	d1 (mm) tolerance
R0.1	±0.01
R0.15	±0.01
R0.2	±0.01
R.025	±0.01
R0.3	±0.01
R0.35	±0.01
R0.4	±0.01
R0.5	±0.01
R0.75	±0.01
R1.0	±0.01
R1.5	±0.01
R2.0	±0.01

Shank (mm) (h6)	d2 (mm) tolerance
Ø 3	0 -0.006
Ø 4	0 -0.008